

THE RELEVANCE OF BRACKETING COAL POWDER USING A PISTON PRESS

Khakimov Akmaljon Akhmedovich

Fergana Polytechnic Institute, Fergana, Uzbekistan

E-mail: n.voxidova@ferpi.uz

Abstract

This study focuses on the development and application of a high-pressure piston press to enhance the usability of coal dust generated during mining and transportation processes. Coal dust, a byproduct often considered waste, poses significant environmental and safety challenges. By implementing a bracketing technique through a piston press, the study aims to compact coal powder into a more manageable and functional form, suitable for industrial and domestic applications. The designed press utilizes advanced materials and engineering principles to withstand high-pressure conditions, ensuring efficient compaction while minimizing energy consumption. Experimental results demonstrate the potential of this technology to reduce waste, improve coal utilization, and mitigate environmental impacts. The findings are significant for industries seeking sustainable and efficient coal management solutions, providing a pathway for resource optimization and environmental conservation.

Keywords: Mines, mining, transportation, coal powder, pressure, press, piston, cylinder, cone rod, form, briquette, strength.

Introduction

Today, coal mining, their transportation and supply of quality fuels for consumers, as well as industries dealing with coal fuels, are one of the main sectors. Compared to drying the moisture in the briquette, it is more convenient to remove the moisture from the coal in the powder state. If the charcoal powder is not dried before bonding, this moisture will combine with the binder moisture during the briquetting process, leading to an increase in the moisture content of the mixture and the formation of residual moisture even after the drying process. The amount of ash without complete combustion and the formation of toxic gases during combustion ensure the quality and exportability of the briquettes produced. Research method to identify existing problems. Manufacturing enterprises operating in our country directly affect the environment and human health by releasing waste products, ie secondary products, directly into the population for consumption or disposal. One of the urgent tasks of the day is to recycle waste from manufacturing enterprises and produce edible products. This research work focuses on the production of fuel briquettes from secondary products that are suitable for consumption. Coal dust generated during coal mining and transportation, alcohol slurry (bard), which is a waste from the distillery, and bean husks, which are waste from the cannery, was used [1-7].



It can be seen that the per capita price of coal briquettes has increased due to the increase in the price of the secondary product and energy consumption. When clay soils were used as binders, the heat level in the combustion process decreased and the amount of ash in them increased. Mainly presses of various constructions are used in briquetting of coal powder. Examples are stamp, roller, ring and revolver presses. Analyzing these presses according to the conditions of use, we can say that the general disadvantages are low productivity, the complexity of the construction structure, high power consumption, uniformity of the size of the pressed briquettes [8-18].

Materials and Methods

In our research work, the work was carried out taking into account these features. Bean husks were used as a binder for coal dust in order to increase the alcohol content and flammability. In the use of coal powder, attention was also paid to its granular composition, and those smaller than 5 mm were isolated. The quality of briquette products depends on the degree to which they are pressed.

The proposed device differs from the existing studied devices in that:

- A high degree of pressing was achieved using the variable step auger in the first auger press,
- secondly, the number of revolutions is variable,
- thirdly, the nozzle part of the press is variable, ie on the basis of consumer demand,
- high level of durability of the fourth briquette product,
- Fifth, high productivity,
- Sixth, the construction is simple

The coal industry includes the processes of coal mining (in some cases beneficiation, briquetting) and delivery to consumers. The most preferred and effective method of coal mining is open pit mining. If the coal deposits are located in a pit, it is mined in a closed (mine) method. Open methods are mainly used in the coal industry of Uzbekistan. This method also has its own drawbacks. For example, due to being in open basins, the moisture content of coal is high, and it decomposes under the influence of atmospheric heat. This results in the formation of fine coal dust in coal mines. This indicator is around 60%.

The rational use of these generated coal powders by consumers poses several challenges. For example, in loading, transportation and use by consumers [19-26].

For example:

An undoubted environmental advantage is the involvement in the processing of waste technical stillage of the Kokand distillery, which is harmful to the environment. As briquette filler, we use solid coal fines or its mixture with carbon -containing biomass. The addition of porous carbon-containing materials (in particular, technical hydrolysis alcohol stillage) and the perforated form of the fuel briquette improve the combustion kinetics. There are additives that catalyze the briquette ignition process (inorganic oxidants, peat, and charcoal). Depending on the characteristics of the briquetted material, schemes are used with the introduction of a binder material and briquetting without it. There are binders of petroleum origin, products of thermochemical processing of coal and binders of a non -hydrocarbon nature. [27-34].



Coal is a sedimentary rock formed over time by a plant, consisting mainly of carbon and a number of other chemical elements.

The composition of coal depends on how many years it has been stored, i.e. its age. In terms of coal classification, brown coal is the youngest coal, followed by hard coal and finally the oldest anthracite. Depending on how much coal is stored underground, there is a decrease in the carbon concentration, volatile components and moisture content. These figures show that the moisture content of lignite is 20-40% and that of volatile components is more than 30%. In anthracite coals, both rates are 5-7%. The moisture content of coal used by consumers today is 25% .

In addition to the main constituents of coal, coal contains various non-combustible ash-forming additives. This condition resists environmental pollution and complete combustion of coal. In addition, the presence of rock in the coal composition reduces the specific combustion temperature of the coal. In the classification and extraction of coal, the amount of minerals in it varies. The ash content varies from 6 to 30%, depending on the time interval between which the coals are stored in the ground. The maximum ash content of brown coal intended for use by consumers is not required to exceed 10% .

Physicochemical properties of Angren brown coal

Name of raw material Humidity, % Ash content, % Organic matter, %

Angren brown coal 25 13.7 61.3

Coal briquettes 7.9 8.5 83.6

Another harmful component of coal is sulfur. During the combustion of sulfur, oxides are released from its composition, which are converted into sulfuric acid in the atmosphere. It poisons and pollutes the environment and forms acidic condensate that breaks down stoves used by consumers. According to environmental requirements, the amount of sulfur in coal is usually allowed in the range of 0.1-1% .

Brown coal has a much lower strength than other types of coal and anthracite. Currently, 80-90% of the coal used by consumers is brown coal. This coal is easy to decompose due to low strength in mining, transportation and operation. Crushed coal grains cause inconvenience to consumers. In order to overcome these problems, various types of briquetting methods are currently being used. In our country, mainly brown coal powder is used in the briquetting process. In Angren coal deposits, this type of coal powder accounts for 50-60%. In these cases, it is convenient to process the resulting coal grains.

Carrying out post-forming heat treatment helps to reduce smoke and increase porosity, but entails additional costs. The factors influencing the briquetting process are moisture content, material size and temperature, pressure and pressing duration. These parameters are closely related to each other. While various wood wastes in the form of sawdust and wood chips can be easily burned in specially adapted long-burning boilers, the situation is different with fine coal and dust. One of the ways to burn coal fines is to melt the boiler with wood, and then pour the dusty fraction of fuel on top of the burning logs. But this is too troublesome business, since coal dust must be added in small portions, which means - often [4]. The best way is to form briquettes from the fine fraction by pressing, which then burn very well, releasing a large amount of heat. Such a solution as coal briquetting was proposed at the beginning of the nineteenth century in Russia by the inventor A.P.Veshnyakov to this day is successfully used



both for industrial purposes and in everyday life. Its essence is that the compaction of fine coal using high pressure on special equipment allows you to obtain fuel, whose calorific value is not less than that of high-quality coals. Coal briquettes are made from brown coal, crumbs and dust of anthracite and coal, semi-coke and coke breeze. Depending on the type of feedstock, binders are added to it or not [35].

Various pressing methods are used in our republic in order to eliminate the emerging problems. Of these, screw, roller and manual pressing devices are being used.

In order to turn coal powder into solid fuel again, it is achieved by placing it in a certain vessel, applying high pressure and adding binders to its content.

Based on the above students, scientific and research work is being carried out to solve these problems at the department of "Technological Machines and Equipment" of Fergana Polytechnic Institute.

A reciprocating press for pressing coal powder along a horizontal axis, developed by us, was designed and constructed. The difference of this device from other presses is that it does not require the addition of additional binders, has high pressure, simple construction and high efficiency.

This device is made up of 3 parts, the first is the driving part, the second is the pressing part, and the third is the coal briquette forming part.

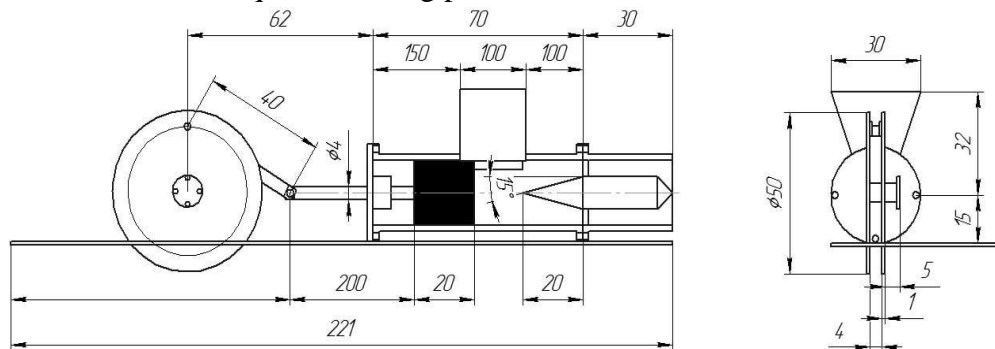

Figure 1. Technological scheme of the pressing process.

Coal powder is brought from coal warehouses and the fraction smaller than 5 mm is sorted. From the rest, the edible ones are separated, and the rest is crushed. After that, the sorted coal powder is dried at a temperature of 80-100 °C and transferred to pressing through a conveyor.

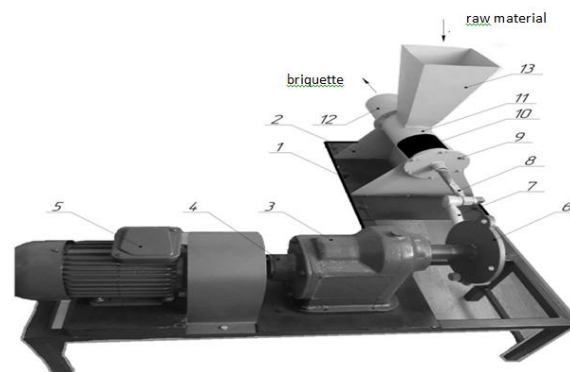

Figure 2. Overview of the device.

The principle of operation of the device: Initially, the electric motor 1 transmits the rotational movement through the clutch 2 to the reducer 3. The reducer 3 transmits the rotational motion to the drive disk 6 at a ratio of 10/1. The driving disk transmits the movement to the shaft 8 through the crank mechanism 7. The rod 8 moves the piston 10 forward and backward. The product is transferred to the press hopper 13, and in the first position of the piston 10, the coal powder is filled into the cylinder 11. When the piston 10 moves to the second position, the hopper 13 is closed by the piston 10, and the pressing operation begins. Then, the forming part, which is the third part of the device, is briquetted due to the compaction of the size of the coal powder given under high pressure in the middle of the conical stirrer installed in the cylinder 12. The briquette coming out of the forming part has a certain length and is used in special automatic cutters to cut it into the required dimensions [36].

In conclusion, it can be said that through the created device, it is possible to find a solution to the emerging problems of providing consumers with solid fuels with a high level of durability, combustible and a certain porosity.

References

1. ХАКИМОВ, А. А. (2022). Технология Получения Качественных Брикетов С Использованием Горючих Вяжущих Компонентов. *Central Asian Journal of Theoretical and Applied Science*, 3(6), 459-463.
2. Hakimov, A., Voxidova, N., & Rajabov, B. (2021). Analysis of collection of coal brickets to remove toxic gas. *Barqarorlik va yetakchi tadqiqotlar onlayn ilmiy jurnali*, 1(5), 85-90.
3. Hakimov, A., Voxidova, N., Rustamov, N., & Madaminov, U. (2021). Analysis of coal bricket strength dependence on humidity. *Barqarorlik va yetakchi tadqiqotlar onlayn ilmiy jurnali*, 1(5), 79-84.
4. Hakimov, A., Voxidova, N., Rajabova, N., & Mullajonova, M. (2021). The diligence of drying coal powder in the process of coal bricket manufacturing. *Барқарорлик ва Етакчи Тадқиқотлар онлайн илмий журналі*, 1(5), 64-71.
5. Hakimov, A., Voxidova, N., & Xujaxonov, Z. (2021). Analysis of main indicators of agricultural press in the process of coal powder bricketing. *Barqarorlik va yetakchi tadqiqotlar onlayn ilmiy jurnali*, 1(5), 72-78.
6. Akhmedovich, K. A. (2021). The Diligence of Drying the Coal Dust in the Process of Obtainig the Coal Brickets. *International Journal of Innovative Analyses and Emerging Technology*, 1(5), 111-115.
7. Hakimov, A., & Vohidova, N. (2021). Relevance of the choice of binders for coal briquettes. *Scientific progress*, 2(8), 181-188.
8. ХАКИМОВ, А. А. (2021). Определение показателей качества угольного брикета. *Universum: химия и биология*, (5-2 (83)), 40-44.
9. Ахунбаев, А. А., Ражабова, Н. Р., & Вохидова, Н. Х. (2020). Исследование гидродинамики роторной сушилки с быстровращающимся ротором. *Экономика и социум*, (12-1), 392-396.
10. ХАКИМОВ, А. А., Вохидова, Н. Х., & Нажимов, Қ. Кўмир брикети ишлаб чиқаришнинг янги технологиясини яратиш. *Ўзбекистон республикаси олий ва ўрта махсус таълим*



вазирлиги Захириддин Муҳаммад Бобур номидаги Андижон давлат университети, 264.

11. Хакимов, А. А. (2020). Связующее для угольного брикета и влияние его на дисперсный состав. *Universum: химия и биология*, (6 (72)), 81-84.
12. Ахунбаев, А., Ражабова, Н., & Вохидова, Н. (2021). Механизм движения дисперсного материала при сушке тонкодисперсных материалов. *Збірник наукових праць SCIENTIA*.
13. Nasiba, V. (2022). High-pressure coal dust pressing machine. *Universum: технические науки*, (7-4 (100)), 17-19.
14. Akhmedovich, X. A., & Saidakbarovna, S. D. (2021). Research the strength limit of briquette production. *Asian journal of multidimensional research*, 10(5), 275-283.
15. Хакимов, А. А., Салиханова, Д. С., Абдурахимов, А. Х., & Жумаева, Д. Ж. (2020). Использование местных отходов в производстве угольных брикетов. *Universum: химия и биология*, (4 (70)), 17-21.
16. Хакимов, А. (2020). Технология брикетированного угля. *Матеріали конференцій МЦНД*, 76-78.
17. Хакимов, А. А. (2020). Совершенствование технологии получения угольных брикетов с использованием местных промышленных отходов: Дисс.... PhD.
18. Khakimov, A. A., Salikhanova, D. S., & Vokhidova, N. K. (2020). Calculation and design of a screw press for a fuel briquette. *Scientific-technical journal*, 24(3), 65-68.
19. Saidakbarovna, S. D., Akhmedovich, K. A., & Abdusattor o'g'li, D. A. (2022). The current state of technologies for the production and activated clay adsorbents. *International Journal of Advance Scientific Research*, 2(04), 25-28.
20. Saidakbarovna, S. D., Akhmedovich, K. A., & O'G, E. U. T. L. (2022). The study of the composition and properties of water-oil emulsions formed from local oils and methods for their destruction. *European International Journal of Multidisciplinary Research and Management Studies*, 2(04), 143-146.
21. Saidakbarovna, S. D., Akhmedovich, K. A., & Ziyovutdin o'g'li, A. S. (2022). The Flotation Methods of Industrial Wastewater Treatment. *Eurasian Research Bulletin*, 7, 80-85.
22. Ахунбаев, А. А., & Хакимов, А. А. (2022). Сушка угольной мелочи перед брикетированием. *Universum: технические науки*, (9-1 (102)), 29-33.
23. Khakimov, A., & Vokhidova, N. (2023). Analysis of industrial waste with binding properties. *Open Access Repository*, 4(03), 113-120.
24. Хакимов, А. А., Вохидова, Н. Х., & Нуриддинов, М. Ж. (2022). Способ выбора и значение прессующего устройства в производстве горючих брикетов.
25. Rukhiddinovna, N. Y., & Akhmedovich, K. A. (2021). Simulated Additional Computer System-As an Information and New Educational Environment in the Vacuation of Future Specialists. *International Journal of Innovative Analyses and Emerging Technology*, 1(7), 30-33.



26. Салиханова, Д. С., Эшметов, Р. Ж., & Хакимов, А. А. (2022). Изучение ассоциатов сопутствующих нефтям веществ и их влияние на стабильность ВНЭ. *European Journal of Interdisciplinary Research and Development*, 9, 88-93.
27. Khakimov, A., & Vokhidova, N. (2023). Characteristic of binders in briquetting brown coal (lignite). *International Journal of Advance Scientific Research*, 3(04), 50-59.
28. Khakimov, A. (2023). The reasonable use of lignite in industry and relevance of obtaining briquettes. *Academia Science Repository*, 4(04), 148-155.
29. Nasibakhon, V. (2024). Analysis of burning time and strength of charcoal briquettes based on tree leaf resin. *Universum: технические науки*, 7(10 (127)), 45-51.
30. Hakimov, A. A., & Alavdinov, S. Z. (2023). Ko'mir kukunini ko'mir kukunini briketlashni samarali texnologik liniyasining ishlab chiqish.
31. Хакимов, А. А. (2024). Актуальность использования связующих при производстве угольных брикетов. *European Journal of Interdisciplinary Research and Development*, 27, 94-98.
32. Хакимов, А. (2024). Кўмир брикетлари олишда органик боғловчилардан фойдаланишнинг долзарблиги. *Новый Узбекистан: наука, образование и инновации*, 1(1), 743-747.
33. Хакимов, А., & Собиров, Х. (2023). Брикетлар тайёрлашнинг ишлаб чиқариш ривожланишига таъсири. *Информатика и инженерные технологии*, 1(2), 254-256.
34. Hakimov, A. A., & Nuriddinov, M. (2023). Ishlab chiqarishda organik bog'lovchilar yordamida ko'mir kukunini biriketlashning dolzarbliги. *Research and implementation*.
35. Hakimov, A. A. (2023). Ko'mir changlarini bog'lovchilar yordamida briketlash orqali ekologik muammolarni xal qilishning ahamiyati: ko'mir changlarini bog'lovchilar yordamida briketlash orqali ekologik muammolarni xal qilishning ahamiyati.
36. Вохидова, Н., & Олимжанов, А. (2023). Намликни йўқотиш орқали ишлаб чиқариш учун сифатли брикетлар тайёрлашнинг долзарблиги. *Информатика и инженерные технологии*, 1(2), 297-299.

